

IRG6B330UDPbF

PDP TRENCH IGBT

Features

- Advanced Trench IGBT Technology
- Optimized for Sustain and Energy Recovery Circuits in PDP Applications
- Low $V_{CE(on)}$ and Energy per Pulse (E_{PULSE}^{TM}) for Improved Panel Efficiency
- High Repetitive Peak Current Capability
- Lead Free Package

Key Parameters		
$V_{CE\ min}$	330	V
$V_{CE(on)}\ typ.\ @\ I_C = 70A$	1.69	V
$I_{RP\ max}\ @\ T_C = 25^\circ C$ ①	250	A
$T_J\ max$	150	°C

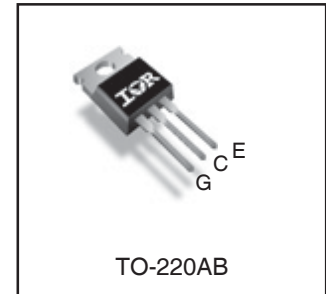
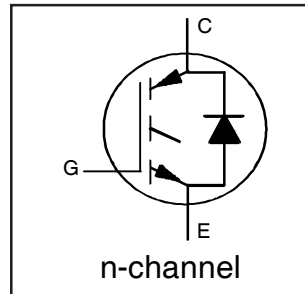

G	C	E
Gate	Collector	Emitter

Description

This IGBT is specifically designed for applications in Plasma Display Panels. This device utilizes advanced trench IGBT technology to achieve low $V_{CE(on)}$ and low E_{PULSE}^{TM} rating per silicon area which improve panel efficiency. Additional features are 150°C operating junction temperature and high repetitive peak current capability. These features combine to make this IGBT a highly efficient, robust and reliable device for PDP applications.

Absolute Maximum Ratings

	Parameter	Max.	Units
V_{GE}	Gate-to-Emitter Voltage	±30	V
$I_C @ T_C = 25^\circ C$	Continuous Collector Current, $V_{GE} @ 15V$	70	A
$I_C @ T_C = 100^\circ C$	Continuous Collector, $V_{GE} @ 15V$	40	
$I_{RP} @ T_C = 25^\circ C$	Repetitive Peak Current ①	250	
$P_D @ T_C = 25^\circ C$	Power Dissipation	160	W
$P_D @ T_C = 100^\circ C$	Power Dissipation	63	
	Linear Derating Factor	1.3	W/°C
T_J	Operating Junction and	-40 to + 150	°C
T_{STG}	Storage Temperature Range		
	Soldering Temperature for 10 seconds	300	
	Mounting Torque, 6-32 or M3 Screw	10lb·in (1.1N·m)	N

Thermal Resistance

	Parameter	Typ.	Max.	Units
$R_{\theta JC}$ (IGBT)	Thermal Resistance Junction-to-Case-(each IGBT) ②	—	0.80	°C/W
$R_{\theta JC}$ (Diode)	Thermal Resistance Junction-to-Case-(each Diode) ②	1.6	2.4	
$R_{\theta CS}$	Case-to-Sink (flat, greased surface)	0.24	—	
$R_{\theta JA}$	Junction-to-Ambient (typical socket mount) ②	—	40	
	Weight	6.0 (0.21)	—	g (oz)

Electrical Characteristics @ T_J = 25°C (unless otherwise specified)

	Parameter	Min.	Typ.	Max.	Units	Conditions
BV _{CES}	Collector-to-Emitter Breakdown Voltage	330	—	—	V	V _{GE} = 0V, I _{CE} = 1 mA
ΔBV _{CES} /ΔT _J	Breakdown Voltage Temp. Coefficient	—	0.34	—	V/°C	Reference to 25°C, I _{CE} = 1mA
V _{CE(on)}	Static Collector-to-Emitter Voltage	—	1.18	1.48	V	V _{GE} = 15V, I _{CE} = 25A ③
		—	1.36	1.68		V _{GE} = 15V, I _{CE} = 40A ③
		—	1.69	2.09		V _{GE} = 15V, I _{CE} = 70A ③
		—	2.26	2.76		V _{GE} = 15V, I _{CE} = 120A ③
		—	1.93	—		V _{GE} = 15V, I _{CE} = 70A, T _J = 150°C
V _{GE(th)}	Gate Threshold Voltage	2.6	—	5.0	V	V _{CE} = V _{GE} , I _{CE} = 500μA
ΔV _{GE(th)} /ΔT _J	Gate Threshold Voltage Coefficient	—	-11	—	mV/°C	
I _{CES}	Collector-to-Emitter Leakage Current	—	2.0	25	μA	V _{CE} = 330V, V _{GE} = 0V
		—	5.0	—		V _{CE} = 330V, V _{GE} = 0V, T _J = 100°C
		—	100	—		V _{CE} = 330V, V _{GE} = 0V, T _J = 150°C
I _{GES}	Gate-to-Emitter Forward Leakage	—	—	100	nA	V _{GE} = 30V
	Gate-to-Emitter Reverse Leakage	—	—	-100		V _{GE} = -30V
g _{fe}	Forward Transconductance	—	50	—	S	V _{CE} = 25V, I _{CE} = 25A
Q _g	Total Gate Charge	—	85	—	nC	V _{CE} = 200V, I _C = 25A, V _{GE} = 15V ③
Q _{gc}	Gate-to-Collector Charge	—	31	—		
t _{d(on)}	Turn-On delay time	—	47	—	ns	I _C = 25A, V _{CC} = 196V R _G = 10Ω, L = 200μH, L _S = 200nH T _J = 25°C
t _r	Rise time	—	37	—		
t _{d(off)}	Turn-Off delay time	—	176	—		
t _f	Fall time	—	99	—		
t _{d(on)}	Turn-On delay time	—	45	—	ns	I _C = 25A, V _{CC} = 196V R _G = 10Ω, L = 200μH, L _S = 200nH T _J = 150°C
t _r	Rise time	—	38	—		
t _{d(off)}	Turn-Off delay time	—	228	—		
t _f	Fall time	—	183	—		
t _{st}	Shoot Through Blocking Time	100	—	—	ns	V _{CC} = 240V, V _{GE} = 15V, R _G = 5.1Ω L = 220nH, C = 0.40μF, V _{GE} = 15V V _{CC} = 240V, R _G = 5.1Ω, T _J = 25°C
E _{PULSE}	Energy per Pulse	—	834	—	μJ	L = 220nH, C = 0.40μF, V _{GE} = 15V V _{CC} = 240V, R _G = 5.1Ω, T _J = 25°C
		—	985	—		L = 220nH, C = 0.40μF, V _{GE} = 15V V _{CC} = 240V, R _G = 5.1Ω, T _J = 100°C
C _{iss}	Input Capacitance	—	2297	—	pF	V _{GE} = 0V
C _{oss}	Output Capacitance	—	141	—		V _{CE} = 30V
C _{rss}	Reverse Transfer Capacitance	—	74	—		f = 1.0MHz, See Fig.13
L _C	Internal Collector Inductance	—	5.0	—	nH	Between lead, 6mm (0.25in.)
L _E	Internal Emitter Inductance	—	13	—		from package and center of die contact

Diode Characteristics @ T_J = 25°C (unless otherwise specified)

	Parameter	Min.	Typ.	Max.	Units	Conditions
I _{F(AV)}	Average Forward Current at T _C =155°C	—	—	8.0	A	
I _{FSM}	Non Repetitive Peak Surge Current	—	—	100	A	T _J = 155°C, PW = 6.0ms half sine wave
V _F	Forward Voltage	—	1.19	1.3	V	I _F = 8A
		—	0.94	1.0		I _F = 8A, T _J = 150°C
t _{rr}	Reverse Recovery Time	—	35	60	ns	I _F = 1A, di/dt = -50A/μs, V _R = 30V
		—	43	—		T _J = 25°C
		—	67	—		T _J = 125°C
Q _{rr}	Reverse Recovery Charge	—	60	—	nC	T _J = 25°C
		—	210	—		T _J = 125°C
I _{rr}	Peak Recovery Current	—	2.8	—	A	T _J = 25°C
		—	6.3	—		T _J = 125°C

Notes:

- ① Half sine wave with duty cycle = 0.1, ton=2μsec.
② R_θ is measured at T_J of approximately 90°C.

- ③ Pulse width ≤ 400μs; duty cycle ≤ 2%.

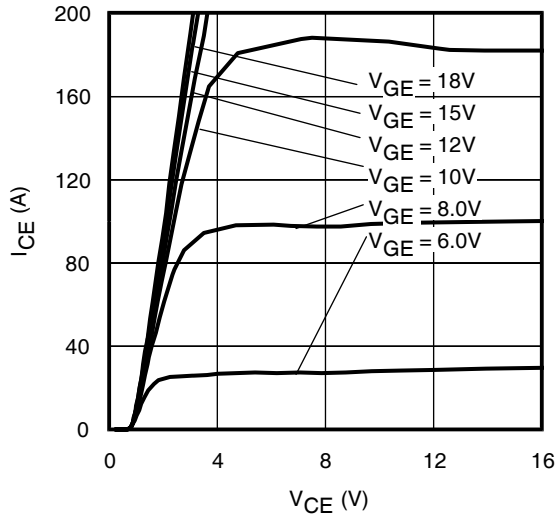

Fig 1. Typical Output Characteristics @ 25°C

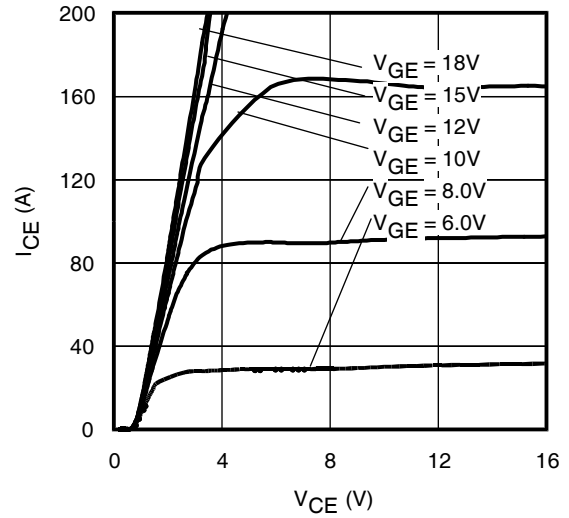

Fig 2. Typical Output Characteristics @ 75°C

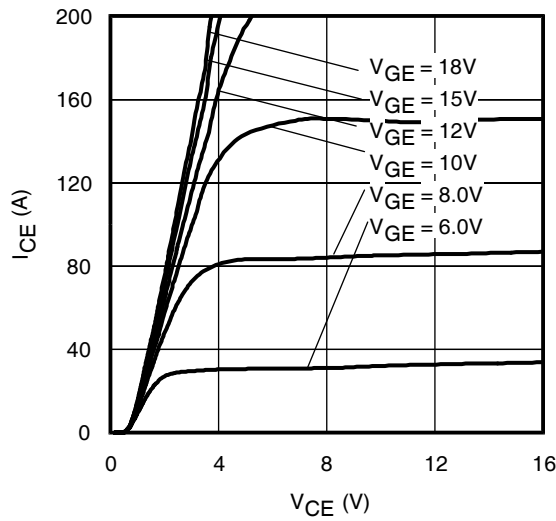

Fig 3. Typical Output Characteristics @ 125°C

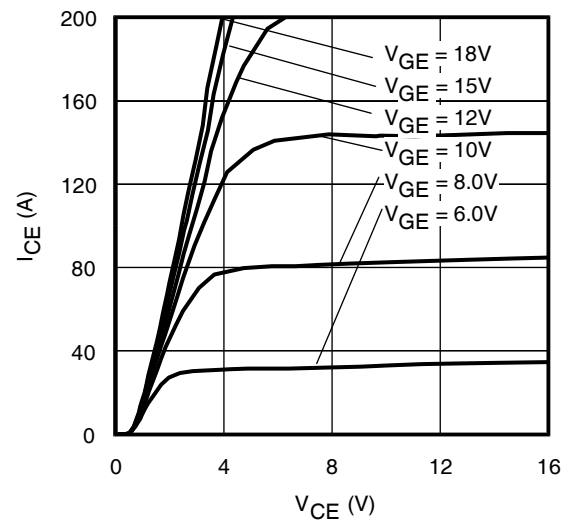

Fig 4. Typical Output Characteristics @ 150°C

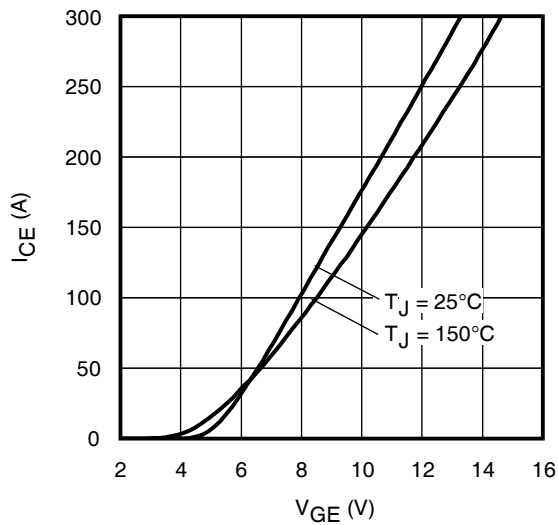

Fig 5. Typical Transfer Characteristics

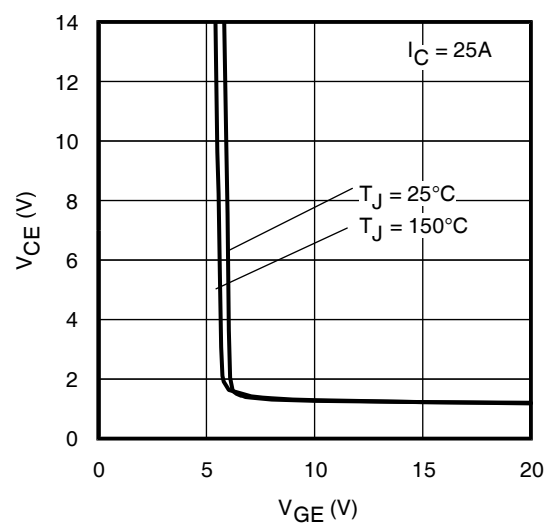

Fig 6. $V_{CE(ON)}$ vs. Gate Voltage

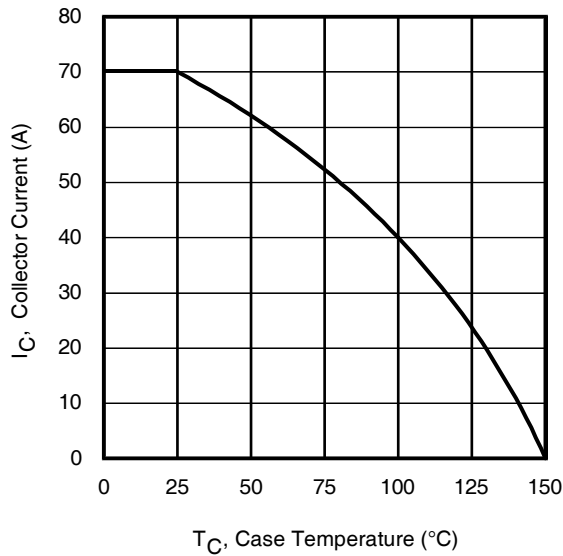

Fig 7. Maximum Collector Current vs. Case Temperature

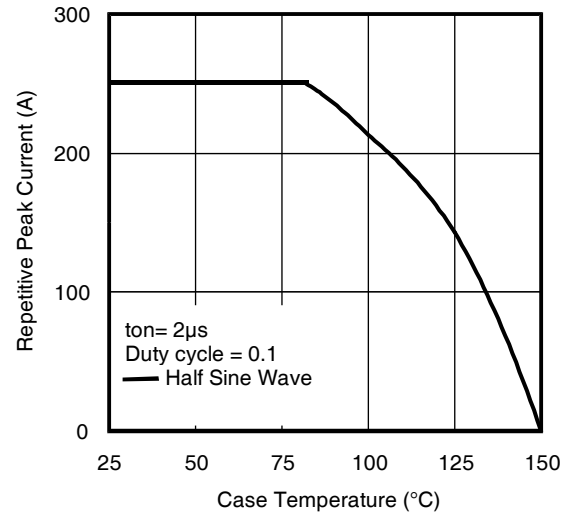

Fig 8. Typical Repetitive Peak Current vs. Case Temperature

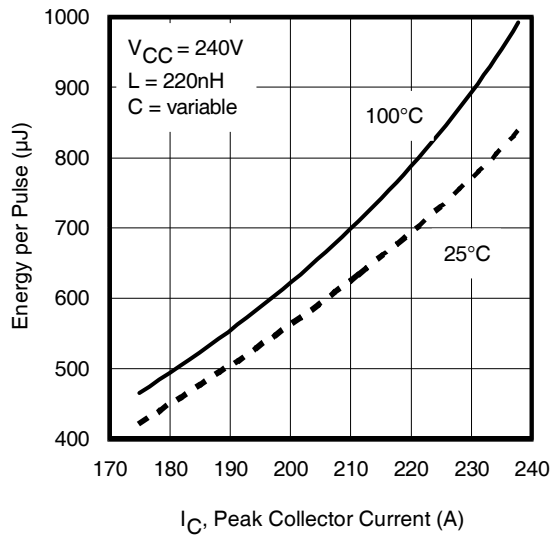

Fig 9. Typical E_{PULSE} vs. Collector Current

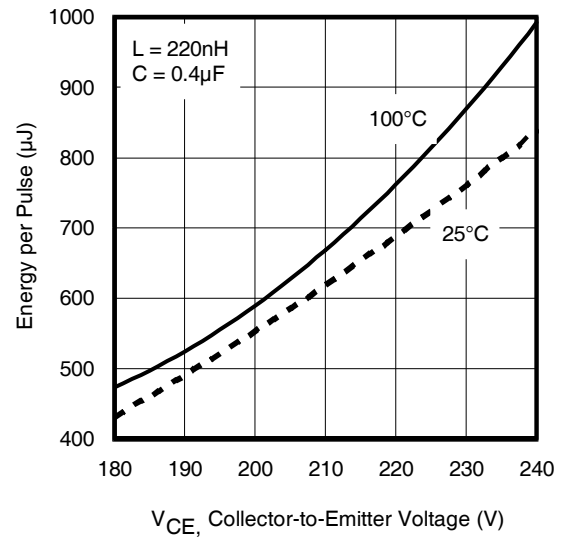

Fig 10. Typical E_{PULSE} vs. Collector-to-Emitter Voltage

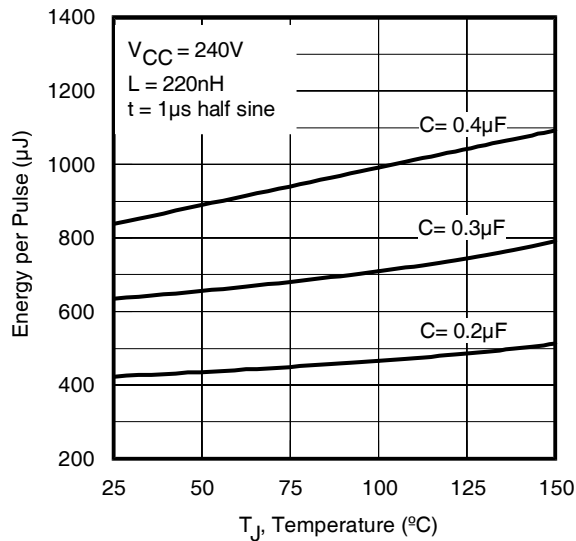

Fig 11. E_{PULSE} vs. Temperature

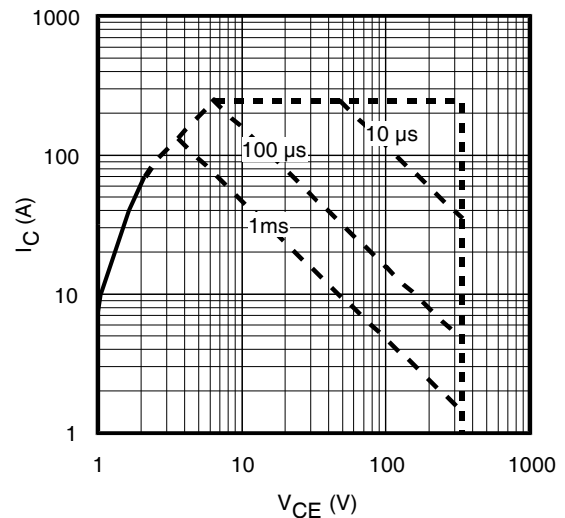

Fig 12. Forward Bias Safe Operating Area

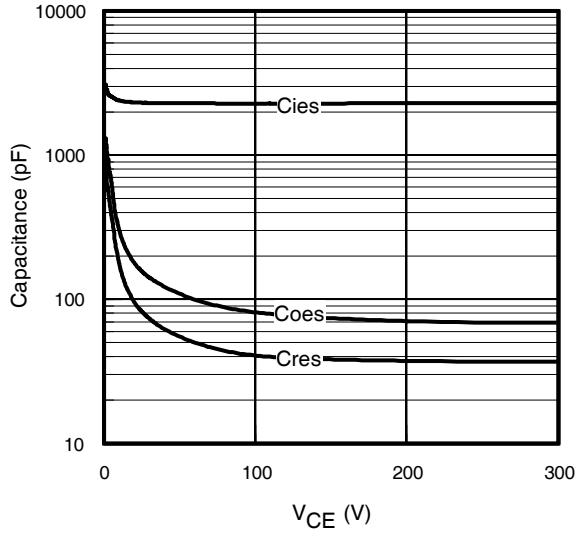

Fig 13. Typical Capacitance vs. Collector-to-Emitter Voltage

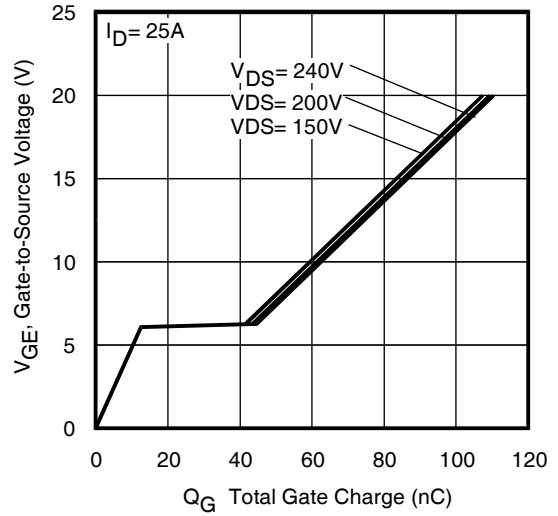

Fig 14. Typical Gate Charge vs. Gate-to-Source Voltage

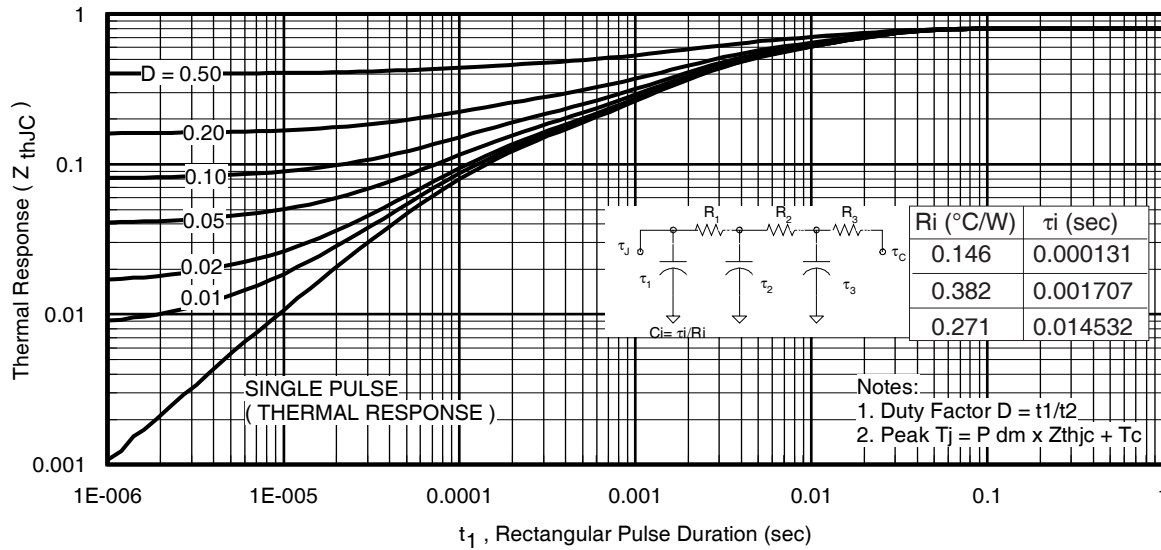

Fig 15. Maximum Effective Transient Thermal Impedance, Junction-to-Case (IGBT)

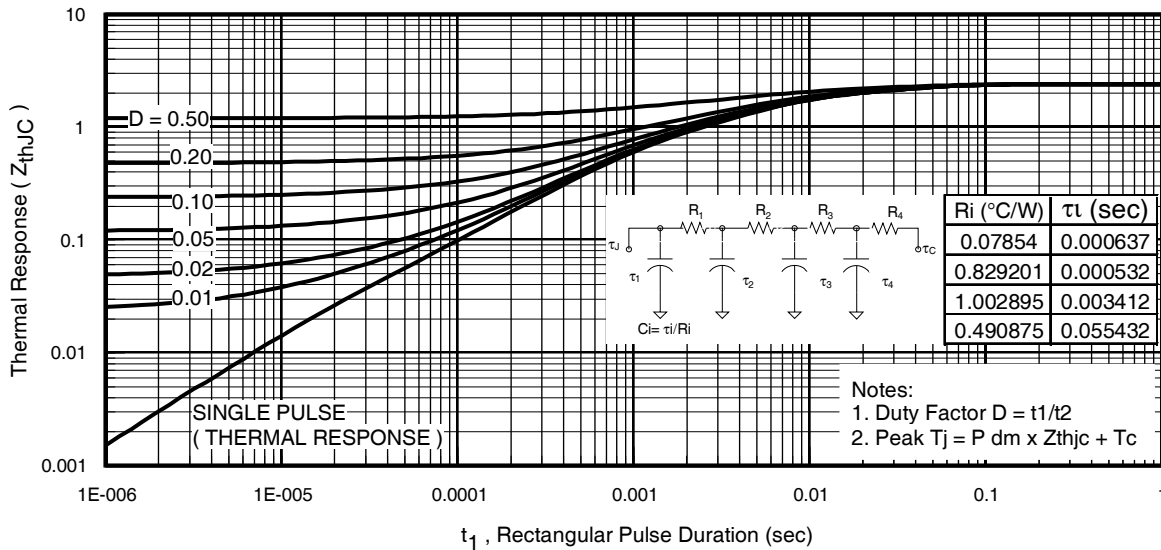

Fig 16. Maximum Effective Transient Thermal Impedance, Junction-to-Case (DIODE)

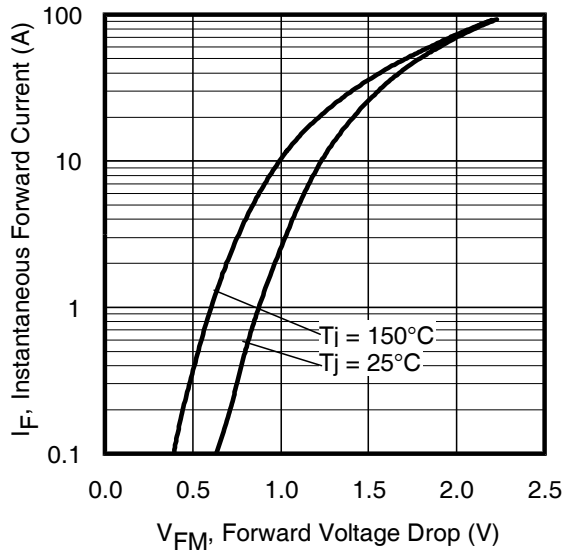

Fig. 17 - Typical Forward Voltage Drop Characteristics

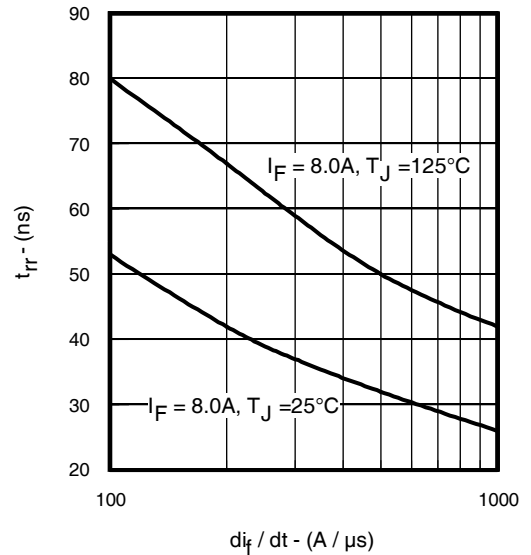

Fig. 18 - Typical Reverse Recovery vs. di_F/dt

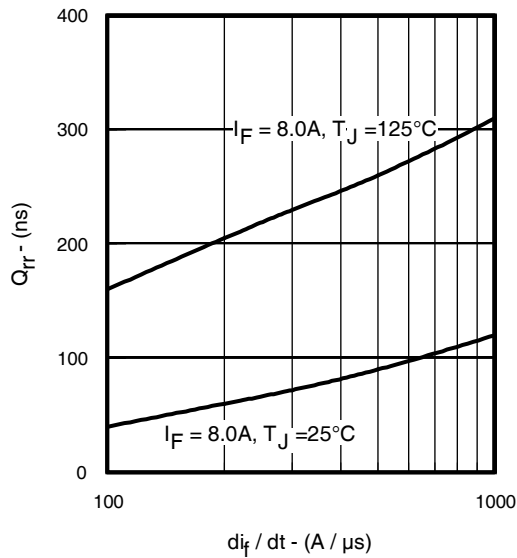

Fig. 19 - Typical Stored Charge vs. di_F/dt

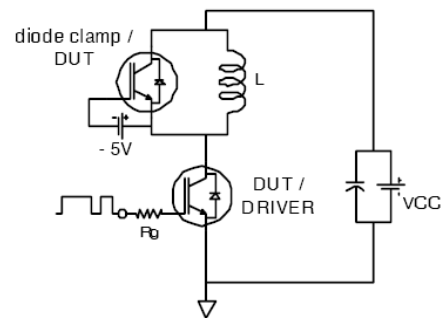

Fig. 20 - Switching Loss Circuit

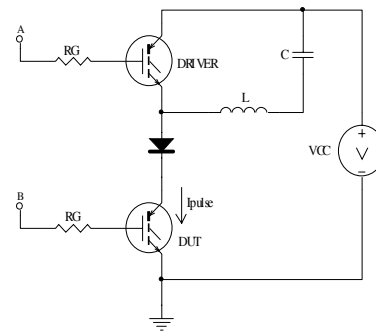

Fig 21a. t_{st} and E_{PULSE} Test Circuit

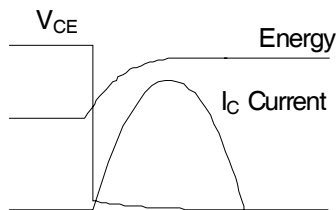

Fig 21b. t_{st} Test Waveforms

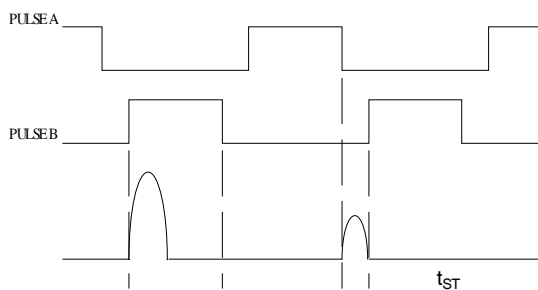

Fig 21c. E_{PULSE} Test Waveforms

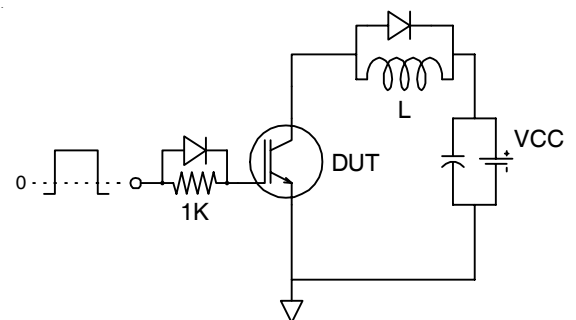
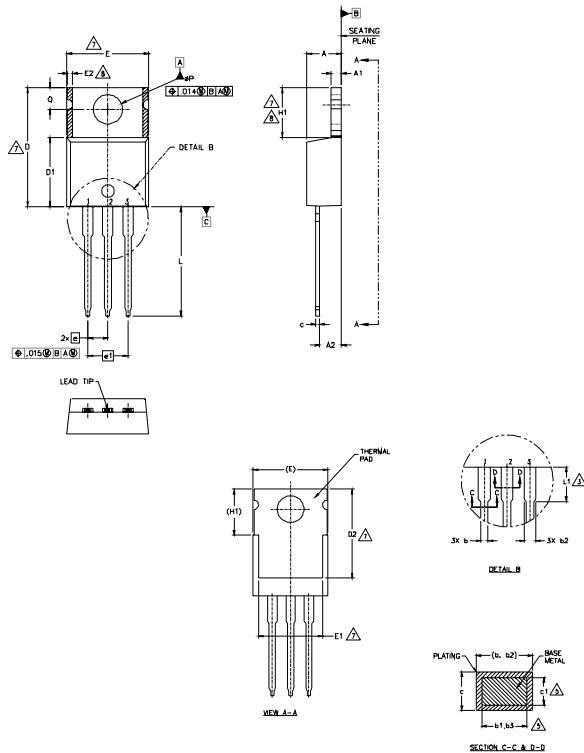

Fig. 22 - Gate Charge Circuit (turn-off)

TO-220AB Package Outline

Dimensions are shown in millimeters (inches)



NOTES:

- 1.- DIMENSIONING AND TOLERANCING AS PER ASME Y14.5 M- 1994.
- 2.- DIMENSIONS ARE SHOWN IN INCHES [MILLIMETERS].
- 3.- LEAD DIMENSION AND FINISH UNCONTROLLED IN L1.
- 4.- DIMENSION D, D1 & E DO NOT INCLUDE MOLD FLASH. MOLD FLASH SHALL NOT EXCEED .005" (0.127) PER SIDE. THESE DIMENSIONS ARE MEASURED AT THE OUTERMOST EXTREMES OF THE PLASTIC BODY.
- 5.- DIMENSION b1, b3 & c1 APPLY TO BASE METAL ONLY.
- 6.- CONTROLLING DIMENSION : INCHES.
- 7.- THERMAL PAD CONTOUR OPTIONAL WITHIN DIMENSIONS E,H1,D2 & E1
- 8.- DIMENSION E2 X H1 DEFINE A ZONE WHERE STAMPING AND SINGULATION IRREGULARITIES ARE ALLOWED.
- 9.- OUTLINE CONFORMS TO JEDEC TO-220, EXCEPT A2 (max.) AND D2 (min.) WHERE DIMENSIONS ARE DERIVED FROM THE ACTUAL PACKAGE OUTLINE.

SYMBOL	DIMENSIONS				NOTES
	MILLIMETERS		INCHES		
	MIN.	MAX.	MIN.	MAX.	
A	3.56	4.83	.140	.190	
A1	0.51	1.40	.020	.055	
A2	2.03	2.92	.080	.115	
b	0.38	1.01	.015	.040	
b1	0.38	0.97	.015	.038	5
b2	1.14	1.78	.045	.070	
b3	1.14	1.73	.045	.068	5
c	0.36	0.61	.014	.024	
c1	0.36	0.56	.014	.022	5
D	14.22	16.51	.560	.650	4
D1	8.38	9.02	.330	.355	
D2	11.68	12.88	.460	.507	7
E	9.65	10.67	.380	.420	4,7
E1	6.86	8.89	.270	.350	7
E2	-	0.76	-	.030	8
e	2.54 BSC		.100 BSC		
e1	5.08 BSC		.200 BSC		
H1	5.84	6.86	.230	.270	7,8
L	12.70	14.73	.500	.580	
L1	3.56	4.06	.140	.160	3
φP	3.54	4.08	.139	.161	
Q	2.54	3.42	.100	.135	

LEAD ASSIGNMENTS

HEXFET

- 1.- GATE
- 2.- DRAIN
- 3.- SOURCE

IGBTs, CoPACK

- 1.- GATE
- 2.- COLLECTOR
- 3.- EMITTER

DIODES

- 1.- ANODE
- 2.- CATHODE
- 3.- ANODE

TO-220AB Part Marking Information

EXAMPLE: THIS IS AN IRF1010
 LOT CODE 1789
 ASSEMBLED ON WW 19, 2000
 IN THE ASSEMBLY LINE "C"

Note: "P" in assembly line position indicates "Lead - Free"

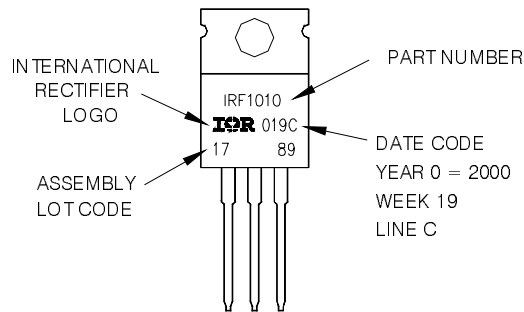

TO-220AB packages are not recommended for Surface Mount Application.

Note: For the most current drawing please refer to IR website at <http://www.irf.com/package/pkight.html>

Data and specifications subject to change without notice.
 This product has been designed for the Industrial market.
 Qualification Standards can be found on IR's Web site.