

THIS DRAWING IS UNPUBLISHED. RELEASED FOR PUBLICATION .19
 © COPYRIGHT 19 BY AMP INCORPORATED. ALL INTERNATIONAL RIGHTS RESERVED.

REV	LOC	QTY	P	F	ZONE	LTR	DESCRIPTION	DATE	APPD
2	BD	39				0	RLSE PER NPR 2454, WAS 89-5898-11	08/18/89	-
			✓	✓		A	OBSOLETE -2 PER ECN BD5374	08/12/91	NS

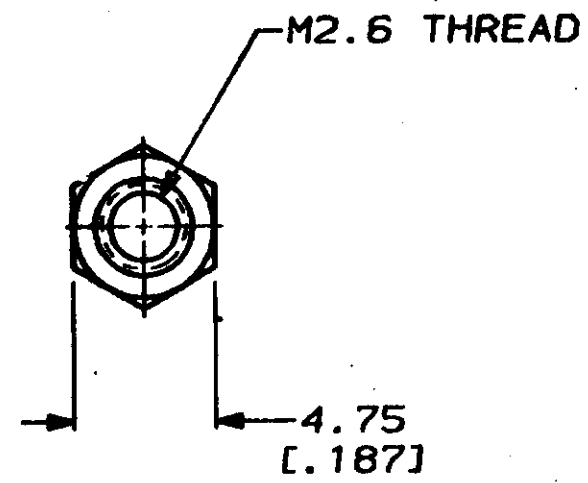
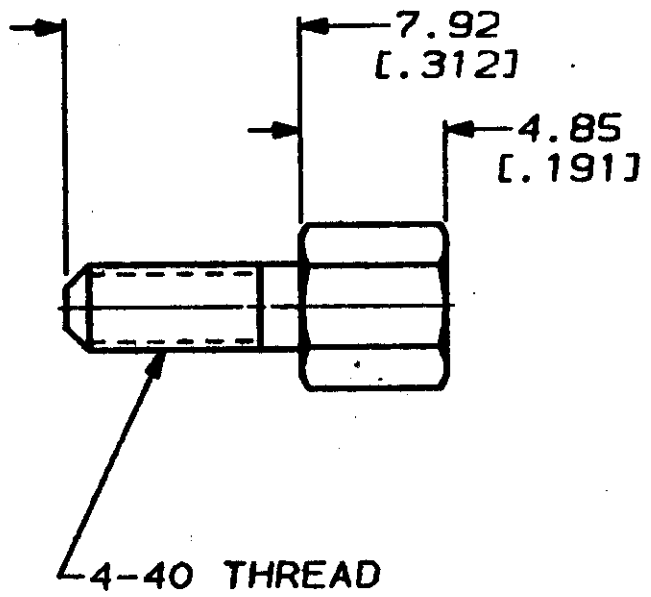

- ① 3.81µm [.000150] MIN ZINC PLATE PER ASTM B633, TYPE II, CLASS SC1, YELLOW CHROMATE.
- ② 3.81µm [.000150] MIN ZINC PLATE PER ASTM B633, TYPE III, CLASS SC1, CLEAR CHROMATE.

	②	749765-3
OBSOLETE	①	749765-2
	FINISH	PART NO

DO NOT SCALE PRINT. UNLESS SPECIFIED DIMENSIONS IN mm (INCHES) TOLERANCES ON: 2 PLC DEC ± 0.13 (.005) 3 PLC DEC ± - ANGLES ± 2°	DR 08/16/89	AMP AMP INCORPORATED Harrisburg, Pa. 17105
	CHK 8-20-89	
MATERIAL	APPD 8-20-89	NAME SCREWLOCK, M2.6 FEMALE, AMPLIMITE®
CARBON STEEL PER ASTM A109	J. NESTRAH	
FINISH	APPD 8-20-89	SIZE
SEE TABLE	J. SHIMERS	B
	PRODUCT SPEC	CAGE CODE
	APPLICATION SPEC	00779
	WEIGHT	DRAWING NO
		749765
		SCALE
		4:1
		SHEET
		1 OF 1

CUSTOMER DRAWING