

Description	Material	Finish
Body	Brass	Nickel
Socket	Be Cu	Gold
Insulation	PTFE	N/A
Gasket	Si Rubber	Rubber
Crimp Ring	Brass	Nickel
Heat Shrink	Polyolefin	Black

REVISIONS			
REV	DESCRIPTION	DATE	APPV
B	Updated dimensions; Added new title block	2-JUL-12	SAH
C	Updated dimensions; Updated note 3	3-JUL-18	CLL

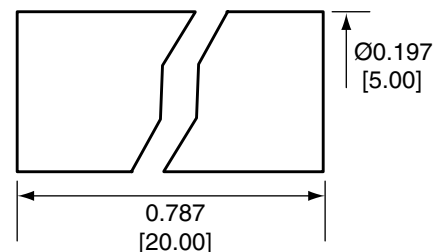
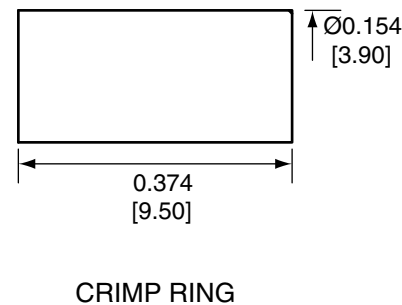
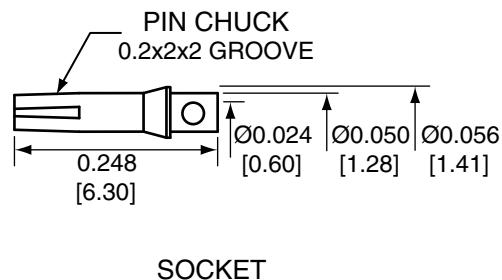
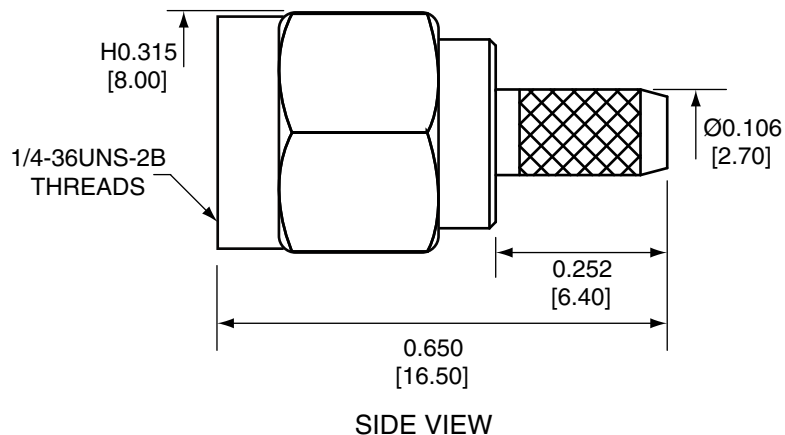

CONREVSMA007 ASSEMBLY INSTRUCTIONS

1. Strip the cable to the recommended dimensions.
2. Slip heat shrink and crimp ring onto stripped cable.
3. Solder the socket to the center conductor.
4. Insert the socket, center conductor, and insulator into the body until the top of the socket is even with the white insulation in the body.
5. Wrap the braid around the tail of the body and crimp the ring with a 0.128" hex crimp tool (or one labeled for use with RG-174 cable).
6. Use heat shrink to cover crimp.

NOTES: (UNLESS OTHERWISE SPECIFIED)

1. ALL DIMENSIONS ARE IN INCHES [mm].
2. DIMENSIONS APPLY AFTER FINISHING.
3. MANUFACTURE TO BE COMPLIANT WITH EU RoHS DIRECTIVE, USE MATERIALS THAT DO NOT CONTAIN REACH SUBSTANCES OF VERY HIGH CONCERN >1000ppm, AND USE DRC CONFLICT-FREE SOURCED MATERIALS.
4. SAFETY BREAK ALL SHARP CORNERS AND EDGES .02 MAXIMUM.

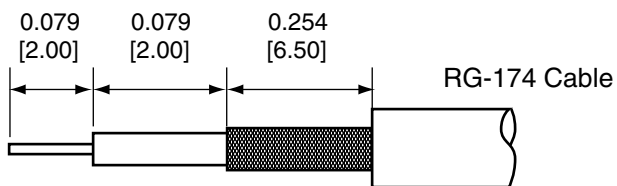

WARNING: THIS DRAWING CONTAINS PROPRIETARY INFORMATION THAT IS THE SOLE PROPERTY OF LINX TECHNOLOGIES, AND SHALL BE TREATED AS SUCH. NO DISCLOSURE OR REPRODUCTION OF THIS DOCUMENT IS PERMITTED, IN WHOLE OR IN PART, WITHOUT THE EXPRESS WRITTEN PERMISSION OF LINX TECHNOLOGIES OR ITS DESIGNATED AGENTS.

MATERIAL:	TOLERANCES: .020 [0.50]-.200 [5.00]= ±.008 [0.20] .200 [5.00]-1.200 [30.00]= ±.016 [0.40] 1.20 [30.0]-4.75 [120.0]= ±.024 [0.60] 4.75 [120.0]-12.40 [315.0]= ±.040 [1.0]	PROJECTION:
FINISH:	DRAWN: B.MURPHY DT: 2-JUL-12	ANGLES: ±1°
	ENGR: S.HOGAN DT: 2-JUL-12	

Linx 159 ORT LANE
MERLIN, OR 97532

TITLE: RP-SMA MALE CABLE END CRIMP FOR RG-174 CABLE		
SIZE A	DWG. NO. CONREVSMA007	REV C
SCALE: 2:1	DO NOT SCALE DRAWING	SHEET 1 OF 1